



Square Peg Product Brief

Communications Inc.

BGAN Forward Demodulator Subsystem (BFDS)

BFDS Features

- Inmarsat compliant BGAN forward signal demodulation
- Full signal acquisition and tracking
- C/C++ software implementation
- Multi-bearer operation: supports one primary bearer and up to 3 secondary bearers
- Provides frame time reference for synchronization of return transmissions
- Code rate detection
- Configurable frequency acquisition range
- Demodulator output statistics available to application
- Compatible with forward equalizer (also available)
- Primary bearer handoff to support hot acquisition

Performance Highlights

- Meets all Inmarsat PER specs, margin > 0.25 dB
- > 48 dB dynamic range in fixed point version
- Meets all initial/cold/warm/hot acquisition and recovery from blockage specifications
- Compliant code rate detection and misidentification performance
- Compliant C/No estimation
- Signal processing latency ~11 ms

MIPS/Memory Requirements

- Avg. Execution Load T4.5X – Trk / Acq
C64x (600MHz) - 5% / 35%
P4 (2.8GHz) - 5% / 33%
- C64x: Program memory – 72 KB
Max Data memory (4xT1Q) – 250 KB

Currently Supported Platforms

- Floating point: Win32 PC, ADSP21160
- Fixed point: TMS320C64x, C64x+

Example BGAN Forward Demodulator Implementation With SPCI BFDS

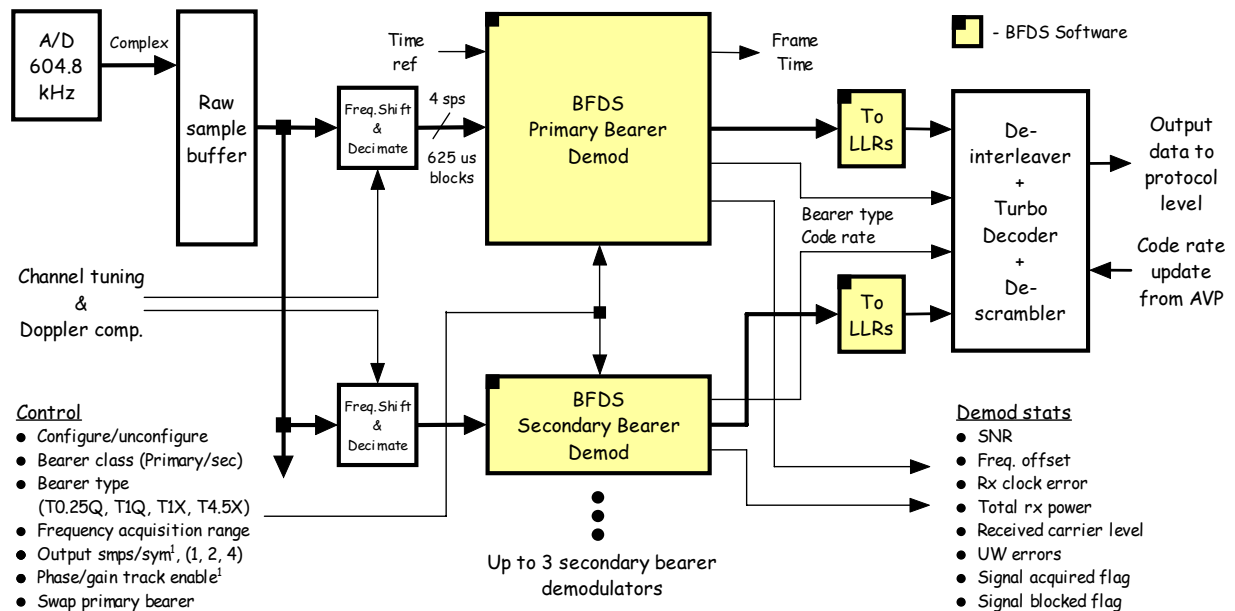

Other software components available. For more information contact: Michael Gertsman, Square Peg Communications Inc., (613) 271-0044, x222, gertsman@squarepeg.ca, www.squarepeg.ca

PER Performance (Non-fading)

- Continuous phase noise (more severe than Inmarsat specification):
 10Hz: -33 dBc/Hz,
 100Hz: -60 dBc/Hz,
 1kHz: -74.5 dBc/Hz,
 10kHz: -79 dBc/Hz,
 100kHz: -87 dBc/Hz

- Discrete phase noise = -30 dBc, 100 Hz
- Phase/gain imbalance = 1.5°, 0.15 dB
- Doppler at 30 Hz/s, max = 48Hz
- Clock error = 5 ppm (3 ppm for T4.5X)
- ACI of +6 dBc at ±10kHz (T0.25), ±40kHz (T1), ±200kHz (T4.5)
- Turbo decoder iterations: 6

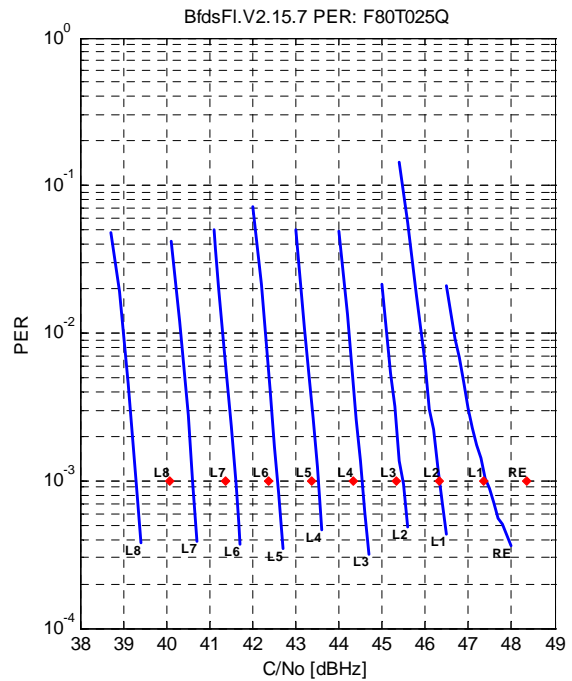
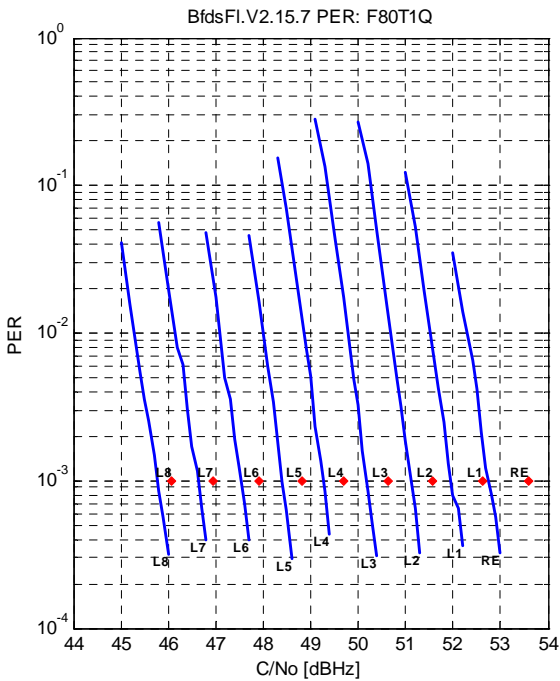
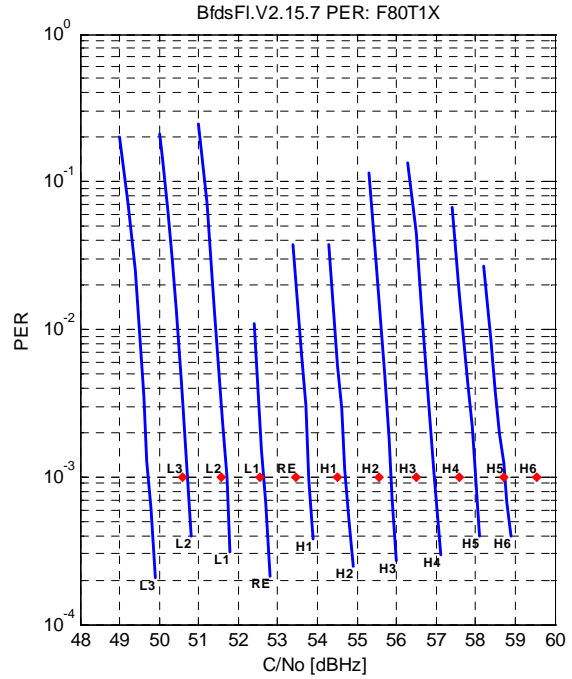
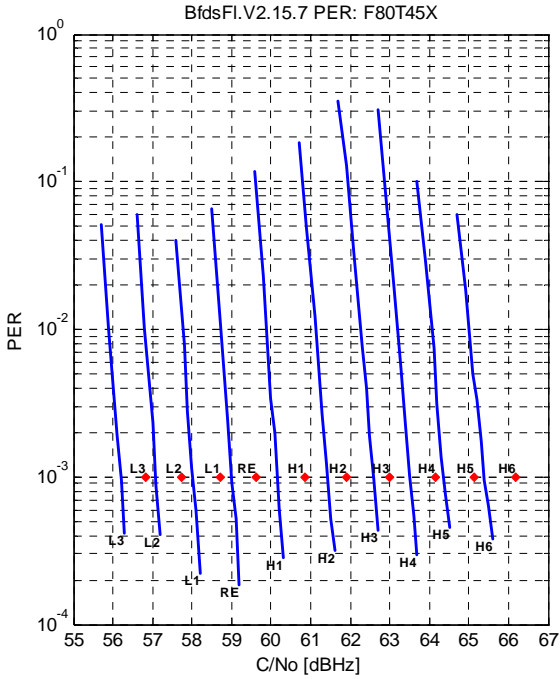

- Note: Red diamonds show Inmarsat specification for each code rate.