

Square Peg

Communications Inc.

Inmarsat NCS/LES Emulator

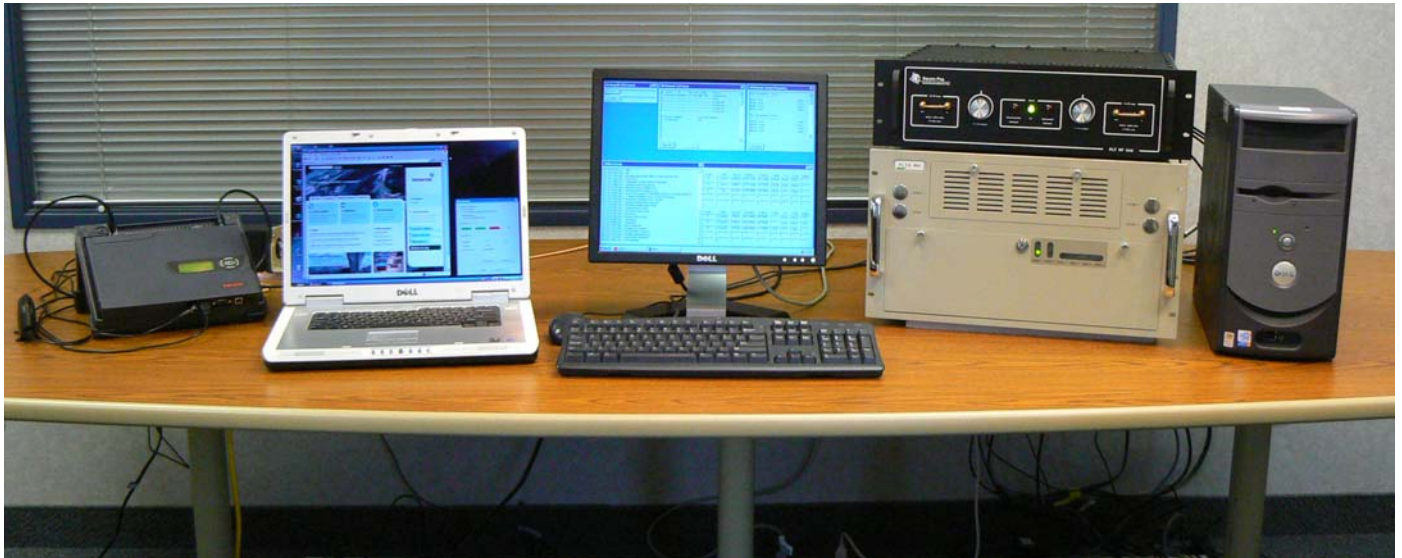

OVERVIEW

The Square Peg Communications Inc. (SPCI) mini-M/M4 Physical Layer Tester (MPLT) supports the testing of MESs for the various flavours of Inmarsat-M4 services including mini-M, GAN, Fleet and Swift64.

The Network Coordination Station / Land Earth Station (NCS/LES) emulator is a software add-on to the MPLT which provides a simple and flexible means of testing MES operation and the operation of end-to-end applications without incurring expensive airtime charges. It can be easily used to test basic terminal operation and standard voice calls as well as end-to-end applications running over ISDN such as TCP/IP for web browsing, email and file transfer or other ISDN applications such as videoconferencing.

The emulator acts as both the NCS and the LES. It transmits NCS and LES TDM channels and receives the MESRQ and MESRP signalling channels from the MES under test. The remaining MPLT channels are used for SCPC data when calls are established.

The emulator maintains a list of valid MESs and handles calls to / from any MES on the list.

Multiple simultaneous calls and multiple MESs are supported, depending upon the hardware available.

The emulator supports the establishment of mini-M voice and ISDN calls in both the to- and from-mobile directions, including dual-hop mobile-to-mobile calls. It also supports looped back voice calls.

Once a call is established, an end-to-end test of the application or service can be carried out. For mini-M voice calls, the MPLT provides one or more mini-M codec interfaces. SPCI Voice Codec Units (VCUs) are connected to these interfaces. The codec provides a standard 2wire or 4wire analog phone connection, enabling end-to-end voice conversation to take place between the LES emulator and the MES handset.

For ISDN calls, an interface card installed in the CU provides an ISDN Basic Rate Interface (BRI), otherwise known as the S/T interface, operating in Network Termination (NT) mode. Various types of ISDN devices can be connected to the NT interface, including routers (e.g., for end-to-end IP connectivity) or an ISDN Terminal Adaptor (e.g., for PCM clear voice calls).

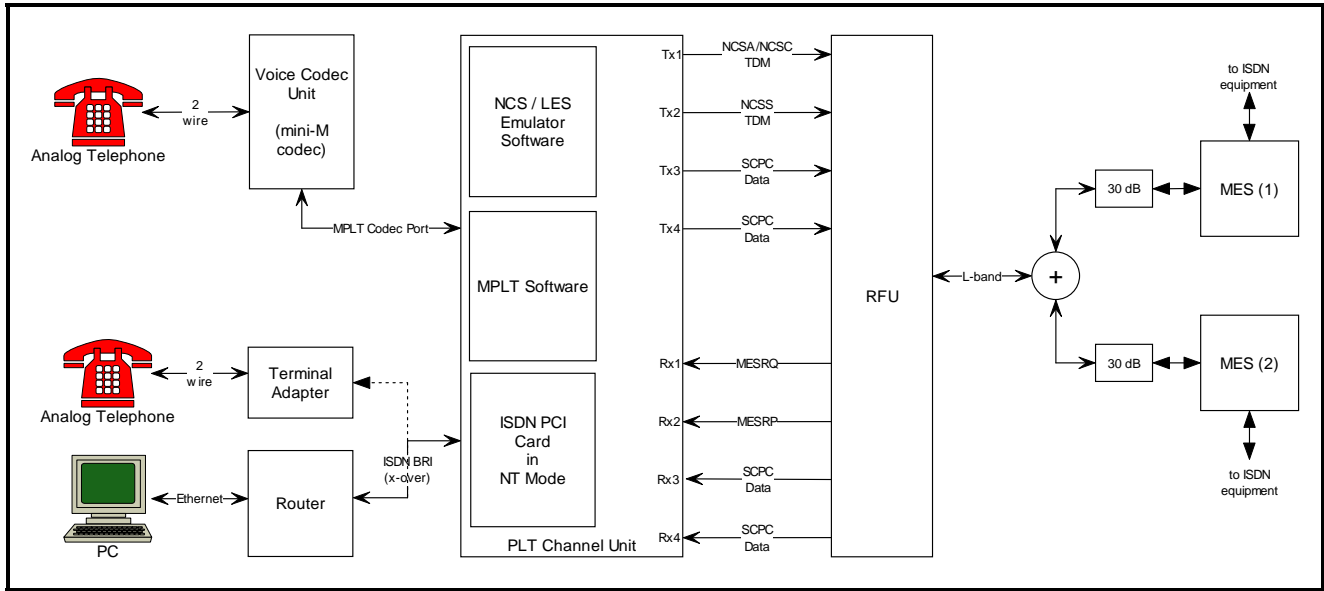

Example NCS/LES Emulator Configuration



SPECIFICATIONS

EMULATOR COMPONENTS

PLT Channel Unit (CU) with Sync I/O interface(s) and ISDN interface	Up to 2 CUs
PLT RFU Unit and high power attenuator(s)	Sync I/O interface required for operation with VCU
MPLT software	One high power attenuator per MES
NCS/LES emulator software	mini-M/M4 Physical Layer Tester
Voice Codec Unit (VCU)	Primary (single CU) Remote (for second CU) AMBE codec with 2W or 4W interface

SUPPORTED SCENARIOS

Terminal types	mini-M GAN Fleet 33/55/77 Swift64
Call types	mini-M voice (4.8 kbps AMBE) M4 / M4 Aeronautical voice (64 kbps PCM) M4 / M4 Aeronautical audio (64 kbps PCM, 3.1 kHz audio) M4 / M4 Aeronautical data (64 kbps UDI)
Maximum number of CUs	2
Maximum number of calls (single hop)	Single CU: 2 Dual CU: 6
Maximum number of calls (dual hop)	Single CU: 1 Dual CU: 3
Maximum number of 64 kbps ISDN calls	Single CU: 2 Dual CU: 4

CALL ROUTING

Mobile-to-fixed	Initiated by MES or equipment attached to MES; dialed number determines terminating interface
Fixed-to-mobile	ISDN: Initiated by ISDN equipment; dialed # determines MES mini-M voice: Initiated via GUI; dialed number determines MES
Mobile-to-mobile	Initiated by MES or equipment attached to MES; dialed number determines terminating MES

EXAMPLE CONFIGURABLE PARAMETERS

Ocean region	Bulletin board
Authorized MESs	Operating frequencies/power Forward/return IDs Signalling (standard or NG) Terminal type (e.g., aeronautical)
Dialing strings for fixed-terminated calls	VCU termination
Dialing strings for mobile-terminated calls	ISDN termination MES Call type / Terminal id



CONTACT Us

For more information contact:

Square Peg Communications Inc.,
4017 Carling Ave.,
Ottawa, Ontario K2K 2A3
CANADA
Tel: +1 613 271 0044 Fax: +1 613 271 3007
Web: www.squarepeg.ca
Email: sales@squarepeg.ca

