



Square Peg

Communications Inc.

Satellite / Wireless Transmit Subsystem (TxS)



OVERVIEW

The Square Peg Communications Inc. (SPCI) Transmit Subsystem (TxS) is a generic, high-availability platform for satellite and wireless communication hubs.

Using the TxS platform, SPCI can quickly and efficiently deliver a satellite or wireless base station solution for any application, with minimal development risk and cost.

The TxS is based on commercial off-the-shelf Compact PCI architecture. Each Compact PCI system is populated with a CPU and a number of SPCI proprietary IF Modem cards that implement the application wireless or satellite channels. IF Modems are DSP-based, allowing them to support a wide variety of channel types, modulation schemes and data rates.

In a complete TxS configuration, two Compact PCI chassis are paired in a redundant Active / Hot Standby configuration. Within each chassis, the TxS application software supports IF Modem redundancy. IF Modem cards and Compact PCI power supplies are both hot-swappable. Together these features ensure extremely high reliability and availability. The TxS can be connected to a wide variety of terrestrial communications networks using standard networking products appropriate to the application.



FEATURES

GENERAL

Description	Generic Satellite / Wireless Communications Platform.
Applications	Interface broadband terrestrial network to wireless / satellite network. Land Earth Station (LES) development platform. Satellite broadcasting base station.
Channel Types	Customizable, supporting data rates of over 300 kbps per IF channel.

FUNCTIONAL

Data Transmission and Reception	<ul style="list-style-type: none">▪ Receive data from terrestrial network and transmit over the satellite / wireless path.▪ Recover satellite / wireless channels and pass data to terrestrial network.▪ Call / protocol processing can be carried out within the TxS Host.
Operator Interface	<ul style="list-style-type: none">▪ Local Windows based Operator Interface.▪ Support for SNMP or other remote Monitor and Control applications.▪ Scripting language allows complex actions to be programmed and re-used.

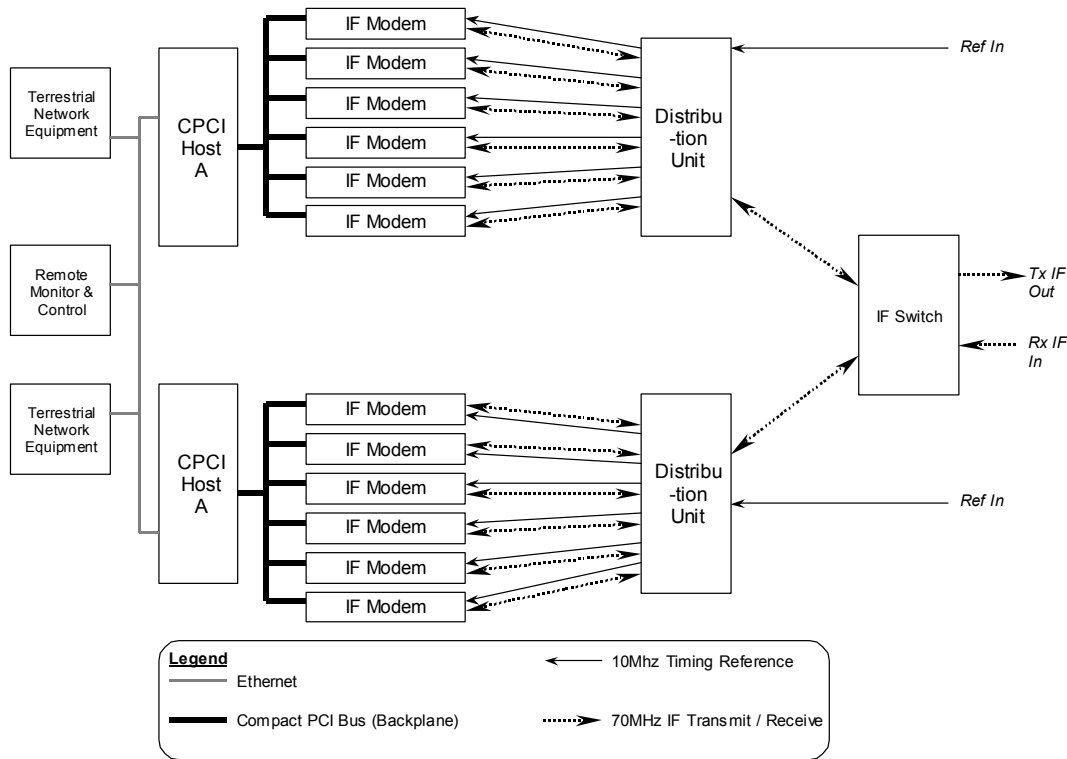

TxS ARCHITECTURE

FUNCTIONAL cont'd

- Redundancy**
- **Host (1:1) redundancy, based on self-monitoring and IF Switch arbitration device.**
 - **Simple and robust redundancy mechanism provides very high availability.**
 - **Configuration automatically synchronized between Hosts.**
 - **IF Modem redundancy within each chassis.**
 - **IF Modem hot-swap support.**

ARCHITECTURE

- Compact PCI Chassis**
- **Two redundant CPCI computer systems.**
 - **Single Intel Pentium family CPU card in each chassis.**
 - **Up to 7 hot-swappable IF Modem cards per chassis.**
 - **Dual, hot-swappable power supplies.**
 - **Hot swappable fan trays.**

- Software Platform**
- **Windows 2000 or XP**
 - **Generic SPCI software platform easily customizable for specific applications.**

- Distribution PCI Unit (DU)**
- **Split and combine IF signals to and from the IF Modems.**
 - **System status LEDs.**
 - **Contact closure output for external alarm systems.**
 - **Multiple DUs can be added to support multiple transmission paths (e.g. multiple satellites).**

- IF Switch Unit**
- **Switches transmit and receive signals between the active system and the transmission path.**
 - **Loops back transmit to receive for inactive system.**

- Networking**
- **Ethernet Switches provide redundant LAN within the TxS.**
 - **WAN Routers provide required terrestrial connectivity.**

IF MODEM

- General**
- **Complete satellite / wireless modem on single CPCI card.**
 - **Single slot, 6U CPCI form factor.**
 - **50-90 MHz IF transmit and receive interface.**
 - **10 MHz reference input.**
 - **Supports multiple channel types, modulation schemes and FEC methods.**
- Hot Swap**
- **IF Modem cards can be removed and replaced in a running system.**
- DSP**
- **TMS 320C6203 DSP processor.**
- Analog**
- **SPCI proprietary upconverter and downconverter modules on card.**



CONTACT US

For more information contact:

**Square Peg Communications Inc.,
4017 Carling Ave.,
Ottawa, Ontario K2K 2A3
CANADA**

Tel: +1 613 271 0044 Fax: +1 613 271 3007

Web: www.squarepeg.ca

Email: sales@squarepeg.ca